

Replace of Hand Pallet Truck

with capacities of 1,500kg

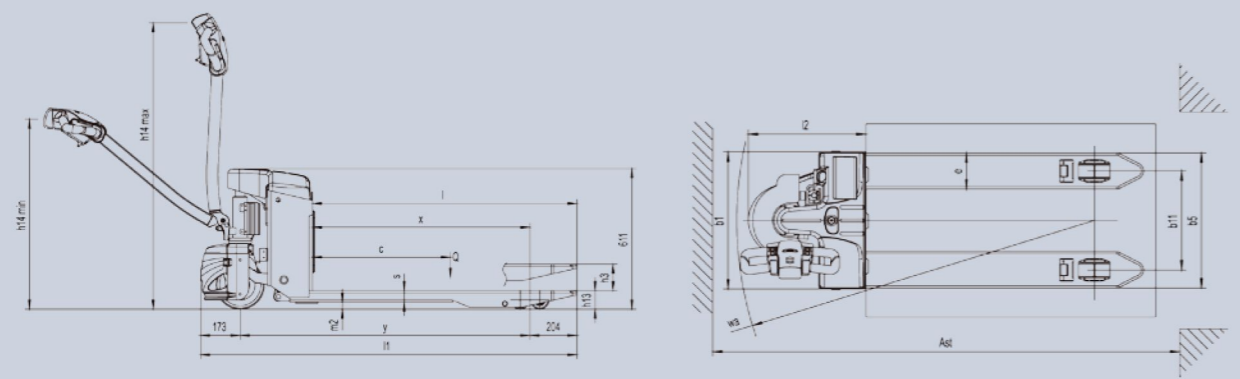

Replace of Hand Pallet Truck

Distinguishing mark	1.1	Manufacturer		HANGCHA GROUP CO.,LTD.
	1.2	Manufacturer's type designation		CBD15-W-SE
	1.3	Drive: electric (battery or mains), diesel, petrol, fuel gas		Semi-electric
	1.4	Operator type: hand, pedestrian, standing, seated, order-picker		pedestrian
	1.5	Load capacity	Q (kg/lb)	1500/3307
Weight	2.1	Service weight	kg/lb	140/309
Tyres, chassis	3.1	Tyre type		PU
Dimensions	4.4	Lift height	h ₃ (mm/in)	115/4.5
	4.15	Fork lowered	h ₁₃ (mm/in)	85/3.3
	4.19	Overall length	l ₁ (mm/in)	1580/62.2
	4.21	Overall width	b ₁ /b ₂ (mm/in)	560/22.0
	4.22	Fork dimensions	s/e/l mm/(in)	50/150/1150 (2.0/5.9/45.3)
	4.25	Outside fork width	b _s mm/(in)	560/685 (22.0/27.0)
	4.34.1	Aisle width,1000×1200 pallet crossways	A _{st} (mm/in)	1697/66.8
4.34.2	Aisle width,800×1200 pallet lengthways	A _{st} (mm/in)	1697/66.8	
4.35	Outer turning radius	W _a (mm/in)	1380/54.3	
Performance data	5.1	Travel speed, laden/unladen	km/h	3.5/4 2.2/2.5
	5.8	Maximum gradeability, laden/ unladen	%	3/6
Electric engine	6.1	Drive motor rating S ₂ 60 min	kW	0.65/0.87
	6.4	Battery voltage/rated capacity	V/Ah	24/24

Application

/ Entry level semi electric pallet truck for your new choice, release the handling strength, reduce the handling cost, decrease manual work.

Safety

/ Handy emergency disconnect button & durable driving unit ensure working safety.

Easy Operating & Maintenance

/ 1.5t load capacity, the most compact design, electric driving and manual lifting with small turning radius to save the operating and working space. Ergonomic design switch box for accurate and easy operating. Built-in charger, maintenance free battery to reduce the maintenance cost. Assembly components are easy for diagnosis and replacing.

Options

- / Fork length - 800/915/1000/1070/1100/1300/1400mm
- / Fork width - 520/600mm
- / Single load wheel
- / Lowered fork height for light load - 75mm/40mm(<1000kg)

High Stability

/ Leading designed handle switch and controller system, revolutionary to reduce the electronic parts defects rate. Unique drive system with high energy-efficiency to increase the reliability deeply. Fitted with hydraulic pump from HPT, reduce the hydraulic system defects rate. Reverse-back button, emergency stop button, slope antiskid resistance, drive wheel cover to increase the safety of the operator.

